

## EMS-96

### Electrical Measurement Supervisor



Information in this document is subject to change without notice and does not represent a commitment on the part of Control elettronica. This documentation is consigned to the customer to enable the correct and safe operation of the instrument; any other use of documentation is strictly prohibited.

The information contained herein is the property of Control elettronica, and by law, no part of it may be reproduced, transcribed, stored in any retrieval system, or translated into any language by means (even for internal purposes by the customer) without the express written permission of Control elettronica.

In addition, no part of this manual may be transmitted in any form by any means, including photocopying and recording, for any purposes, without the express written permission of Control elettronica. In case of Copyright violation the customer is directly responsible.

## TERMS OF WARRANTY

The warranty is valid for the period of 24 months after material receipt.

The warranty covers free repair or replacement of equipment parts, which are recognized as faulty due to manufacturing defects.

Warranty does not cover those parts which results defective due to misuse or improper use, incorrect installation or maintenance, operation by unauthorized personnel, damage during transportation, or which in any case do not show manufacturing defects of the equipment.

Not included in the warranty terms are technical interventions regarding equipment installation to electrical systems.

The manufacturer declines any responsibility for eventual injury or damage to persons, animals or things as result of failure to follow the instructions in the user manual or caused by improper use of equipment.

The expenses of transport as well as the relative risks of same both to and from the place of repair, will be the sole responsibility of the user.

This warranty expires after the date of purchase and any assistance required after said date including spare parts, labour, transport of personnel and material will be charged to the user following the tariffs in force for Technical Assistance Service at the time of such requested service.

In any case the replacement of the equipment as well as the extension of warranty after such breakdown is excluded.

## Safety information

### Important information

Read these instructions carefully and look at the equipment to become familiar with the device before trying to install, operate, service or maintain it. The following special messages may appear throughout this bulletin or on the equipment to warn of potential hazards or to call attention to information that clarifies or simplifies a procedure.



This is the safety alert symbol. It is used to alert you to potential personal injury hazards. Obey all safety messages that follow this symbol to avoid possible injury or death.

### Please note

Electrical equipment should be installed, operated, serviced and maintained only by qualified personnel. No responsibility is assumed by Control elettronica for any consequences arising out of the use of this material.

A qualified person is one who has skills and knowledge related to the construction, installation, and operation of electrical equipment and has received safety training to recognize and avoid the hazards involved.

### Document scope

This manual is intended for use by designers, system builders and maintenance technicians with an understanding of electrical distribution systems and monitoring devices.

### Safety precautions

Installation, wiring, testing and service must be performed in accordance with all local and national electrical codes. Carefully read and follow the safety precautions outlined below.

## DANGER

### HAZARD OF ELECTRIC SHOCK, EXPLOSION

- Apply appropriate personal protective equipment and follow safe electrical work practices.
- This equipment must only be installed and serviced by qualified electrical personnel.
- Turn off all power supplying this device and the equipment in which it is installed before working on the device or equipment.
- Always use a properly rated voltage sensing device to confirm power is off.
- Before performing visual inspections, tests, or maintenance on this equipment, disconnect all sources of electric power. Assume that all circuits are live until they have been completely de-energized, tested and tagged. Pay particular attention to the design of the power system. Consider all power supply sources, particularly the potential for back-feed.
- Do not exceed the device's ratings for maximum limits.
- Never short the secondary of a voltage transformer (VT).
- Never open circuit a current transformer (CT).

**Failure to follow these instructions will result in death or serious injury.**

### UNINTENDED OPERATION

Do not use the meter for critical control or protection applications where human or equipment safety relies on the operation of the control circuit.

**Failure to follow these instructions can result in death, serious injury or equipment damage.**

## Introduction

The EMS-96 has advanced analysis functions that allow the measurement of the main electrical parameters: voltage, current, frequency, power factor, crest factor, active and reactive power, active and reactive energy. The instrument allows the measurement and analysis in real time of electrical parameters, also verifying the quality of the energy thanks to THD measurement. Bidirectional metering of energy allows both production and consumption of energy to be monitored with a single device. All information monitored by the analyzer can be transmitted to remote locations through communication interfaces RS485, Ethernet, Profibus DP, MBUS, IEC61850.

The EMS-96 series are used to measure electrical parameters of an installation or a part of an installation.

This function meets the requirements for:

- installation monitoring and monitoring the power quality,
- alarming on consumption drifts or measurements threshold,
- consumption monitoring,
- individual voltage/current harmonics up the order 21<sup>th</sup>,
- dips, interruptions, swells,
- password protection,
- graphics consumption.

## Configuration

	STD	OPTIONS								
Housing	96x96mm	96x96mm RINA								
AUX supply	90÷250 Vac/dc	20+60 Vac/dc								
Current inputs	1A / 5A <sup>(1)</sup>	1A & 5A + Neutral <sup>(1)</sup>	1A & 5A <sup>(2)</sup>	Rogowski <sup>(3)</sup>	Rogowski + Neutral <sup>(3)</sup>	TTA 50A <sup>(4)</sup>				
I/O	2 DO	4 DO 4 DI	6 DO 2 DI	8 DO	4 DO 2 AO <sup>(5)</sup>	4 DO 4 AO <sup>(5)</sup>	8 DI 2 DO <sup>(5)</sup>	4 AI	2 PT100	2 AI 1 PT100
I/O type	DO photo-mos	DO: photo-mos DI: 24 Vac/dc	DO: photo-mos DI: 48 Vac/dc	DO: photo-mos DI: 115 Vac/dc	DO: photo-mos DI: 230 Vac/dc					
Communication	RS485(COM1)	RS485(COM1) RS485(COM2)	RS485(COM1) Profibus	RS485(COM1) MBUS	ETHMOD <sup>(6)</sup>	RS485(COM1) ETHMOD <sup>(6)</sup>	RS485(COM1) ETHWEB <sup>(7)</sup>	RS485(COM1) IEC61850		
Accuracy	1	0.5S	0.2S							
SW options	STD	H (Harmonics)								

**NOTE:** It's possible select only one option for each row. The selected option replaces the standard configuration.

(1) 5mm - removable terminal block - 10mA+5A [in class] - Imin read 1mA - Vmin read 1V

(2) 10mm - fixed terminal block - 10mA+5A [in class] - Imin read 1mA - Vmin read 1V

(3) 0.7mV÷350mV [see class] - Vmin read 0,1mV

(4) 0.1A÷50A

(5) 8DI with one common pin

(6) ETHMOD version makes available Modbus TCP/IP communication available only. [the ethernet connector is located on the upper side of the box in the advanced area]

(7) ETHWEB version makes available Modbus TCP/IP communication and the visualization on web pages of the main measures (through the webserver inside the instrument).

[the ethernet connector is located on the back of the box above the serial ports]

(8) Analog outputs available in two options: (I) only current outputs (V,I) voltage and current outputs

## Software version

	STD	H (Harmonics)
Waveforms	NO	yes
Harmonics	NO	up the order 21 <sup>th</sup>
Voltage dips / Voltage swells	NO	no
Voltage interruption	NO	no

To enable one or more option, it's necessary to input a code in the instrument setup (*Setup* → *General* → *Password* → *Enable options*). To get the code it is necessary to provide the serial number at the time of the request made to the retailer.

Note: if the options are requested at the time of ordering it is not necessary to enter any code.

## Software features

	Range
Measurement refresh [V, A, W, VAR, Hz]	~ 1000 ms
Modbus RTU response (38400 - 32 registers)	< 100 ms
Modbus TCP/IP response (MOD-TCP version)	< 100 ms
Ping (local network)	Min = 4; Avg = 4; Max = 4;
Profibus measurement refresh	~ 1000 ms
Activation DO between setpoint	~ 1000 ms
Analog output refresh	<50 ms (on request)

## Connection of the device

### Auxiliary power supply

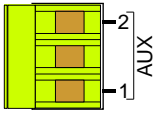

The instrument can be supplied with a voltage independent by the monitoring line. In this case, the instrument continues to operate independently by the voltage present on the lines under control.

Alternatively, only for 90÷250Vca/cc version, it is possible to take the power from the network under test, using the phase and neutral for a 4-wire network, phase to phase in a 3-wire system without neutral or from a VT in a MT application. In this case when the voltage of the monitored line falls below the minimum limit, the instrument turns off.

### Voltage inputs

**Note: To detect the frequency of the network the terminal VL1 must be always connected**

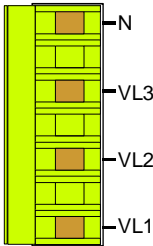

4 terminals are available for direct connection to 3 phase network with neutral. In case of a 3 phases balanced system without neutral, or not distributed neutral to leave terminal N free.

3 inputs, range 30 ÷ 400Vac phase to neutral - 52 to 693Vac phase to phase (see Technical Features table for details); over these values must used the external voltage transformers.

Frequency range: 50/60Hz.

Permanent overvoltage allowed: 480Vac phase to neutral - 830VAC phase-phase.

Overvoltage category: II (permanent installations).

Pollution degree: 2 (normally non-conductive, conductive condensation temporary).

Input resistance: > 1.8MΩ.

Load (Burden) for each voltage input: 0.09VA.

### Current inputs

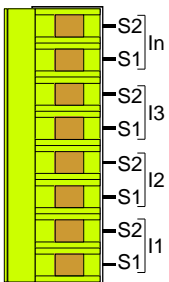

Current measurements can be performed by connecting the terminals of Current inputs.

All current inputs are isolated by current transformers with different ranges depending on the model of the instrument.

They can be interfaced directly to the line to be monitored or to be connected to the output of external CT with higher range.

The connections to the lines to be monitored are described in chapter "Wiring diagrams".

With neutral current input option installed, the instrument allows the direct measurement of neutral current in the same way described for the line inputs.

**Note: it is essential to observe the correct phase sequence, not invert the connections between the phases of the current inputs and voltage (i.e. the CT placed on L1 phase must absolutely match at I1 Current and VL1 voltage). Do not invert the terminals S1 and S2 of the CT because the measurement of power factors, and the powers would no longer be trusted.**

Neutral Current: the nominal current range depends by the version.

### Digital inputs / Digital outputs

4 digital outputs (4DO)  
2 analog outputs (2AO)  
4DO+2AO

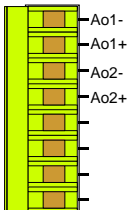

4 digital outputs (4DO)  
4 analog outputs (4AO)  
4DO+4AO



4 digital outputs (4DO)  
4 digital inputs (4DI)  
4DO+4DI

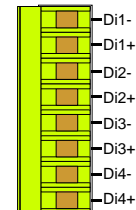

6 digital outputs (6DO)  
2 digital inputs (2DI)  
6DO+2DI

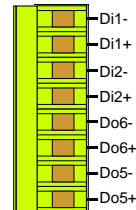

8 digital outputs (8DO)  
8DO

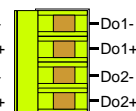
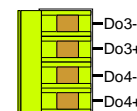
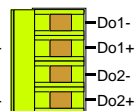
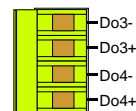
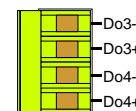
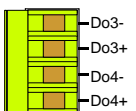
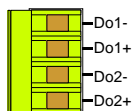
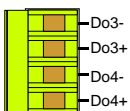
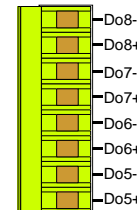

## RS-485 connector

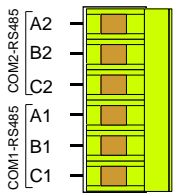

Depending on the version, the instrument can be equipped with one or two isolated half duplex RS485 serial interface. With these options the instrument can communicate with the external with the Modbus protocol. The two ports are independent and they can perform the same operations. The presence of the serial port RS485 allows the software update.

The instrument communicates via an asynchronous isolated serial interface in the standard RS485 Half-duplex that allows a connection in a network up to 247 nodes. This allows to implement a communication network between different instruments and a master unit (data concentrator) for a detailed control of an electrical installation.

The maximum length of the line depends on variables such as the transmission rate and characteristics of the cables used. It's recommend to use a shielded twisted pair cable with low attenuation, with a minimum section of 0.36mm<sup>2</sup> (22AWG) and capacity of less than 60pF / m. The maximum length is about 1200m. For longer distances it's need to use signal amplifiers (repeaters). High networking

length and/or where environments are electrically "noisy", it requires the use of two termination resistors (at the beginning and end of the line) of 100-120Ω. The use of repeaters is also necessary in the case of networks with more than 32 nodes. At each repeater can be connected 32 units.

Please note that complex networks with large number of nodes cause a slower speed of response by the instruments.

Connection type: half-duplex (2 wires + common).

Insulation: opto-couples (3750 Vrms min.).

In the figure is showed a connection with a not shielded cable. In the shielded cable connection it's necessary to connect the shield to COM terminal.

## Modbus TCP connector

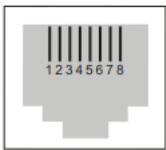

**ETH-MOD (connector above of the enclosure):** The RJ45 connector incorporates 2 LED. The green LED of Ethernet status, Link/Data, is turned on when the Ethernet cable is plugged into the device. The LED blinks whenever a Modbus TCP query is received.

**ETH-WEB (connector on the back of the enclosure):** Embedded web server and Modbus TCP.

## Profibus DP connector

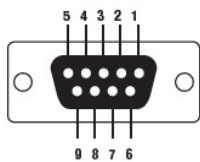

Profibus-DP is a multi-master systems. In the networks it's possible to have up to 126 devices on the same bus. In profibus-DP networks, the interchange of data between peripheral modules and the master is made automatically by the profibus controller, which 'virtualise' the data exchange memory of the DP devices in the memory of the master. In the following picture the pin-out of the Profibus-DP port: 9.6 Kbit/s, 19.2 Kbit/s, 45.45 Kbit/s, 93.75 Kbit/s, 187.5 Kbit/s, 500 Kbit/s, 1.5 Mbit/s, 3 Mbit/s.

It is possible to request application examples, protocol and GSD in order to simplify the installation of the instrument.

Pin	Assignment
1	N.C.
2	N.C.
3	Profibus D+
4	RTS
5	GND
6	5V
7	N.C.
8	Profibus D-
9	N.C.

Meaning of the LEDs on the back of the instrument:

- LED Par flashing: instrument not parametrized;
- LED Par on: instrument parametrized correctly;
- LED ExB on: active data exchange;
- LED ExA on: no communication;

## M-Bus

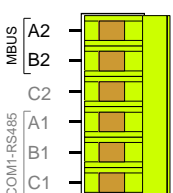

The wiring is performed using two conductors (MBUS1 and MBUS2 connected to A2 and B2) that are used for the data transmission and power supply of the MBUS communication module. The connection is independent of the polarity.

## Wiring connection



**Warning:** If the instrument has the TT.. or TTA.. current inputs, do NOT connect the S2 terminals to the earth.

(1) Three-phase measuring, four conductors, unbalanced load, without voltage transformers, with current transformers.

### Connection type 3PH-4W

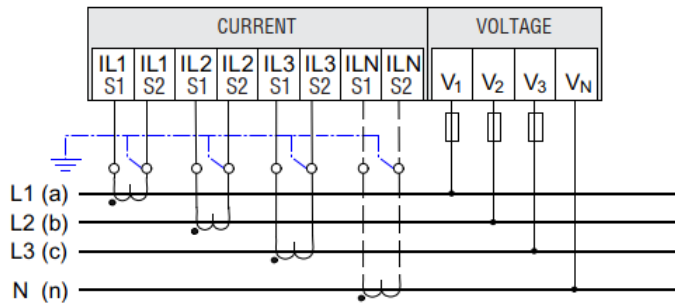

(2) Three-phase measuring, three conductors, unbalanced load, without voltage transformers, with two current transformers. (ARON)

### Connection type ARON

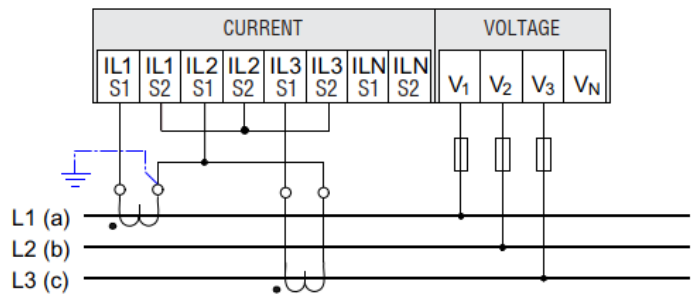

(3) Three-phase measuring, three conductors, unbalanced load, with voltage transformers, with two current transformers. (ARON)

### Connection type ARON

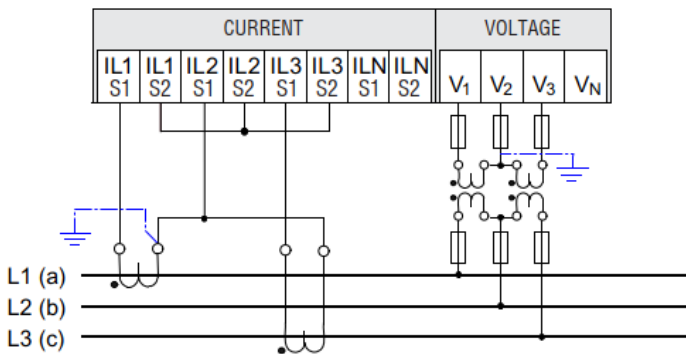

(4) Three-phase measuring, three conductors, balanced load, without voltage transformers, with one current transformer.

### Connection type 3PH BAL

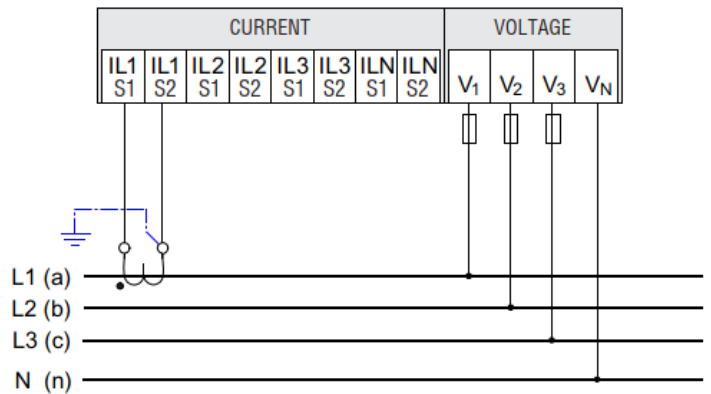

(5) Three-phase measuring, four conductors, balanced multiple loads, with three current transformers.

### Connection type 3PH ML BAL

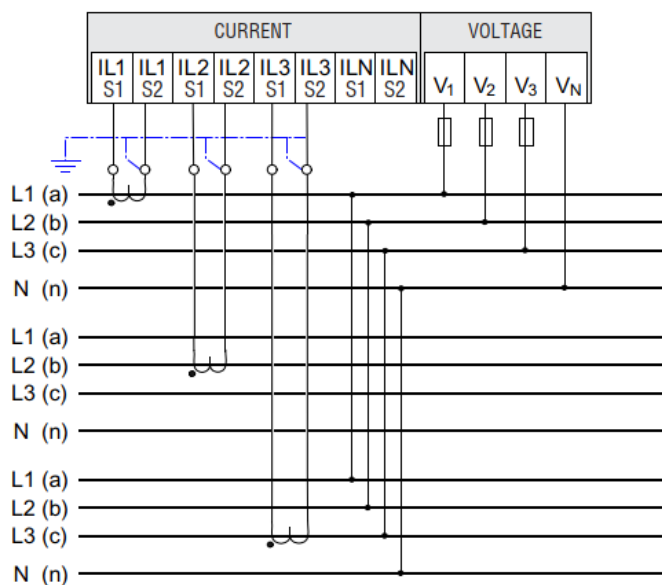

(6) Single-phase measuring, two conductors, without voltage transformers.

### Connection type 1PH

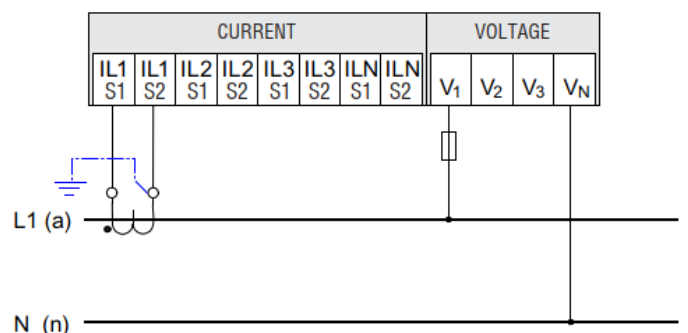

(7) Single-phase measuring, two conductors, without voltage transformers, with one current transformer.

**Connection type 1PH ML**

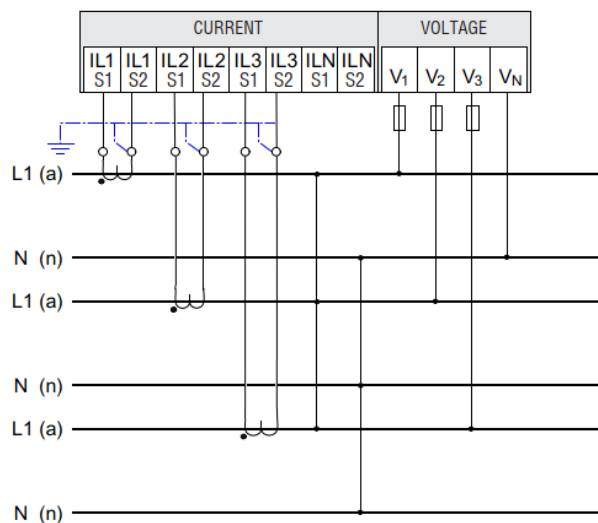

(8) Two-phase measuring, three conductors, unbalanced loads, without voltage transformers with two current transformers.

**Connection type 2PH 3W**

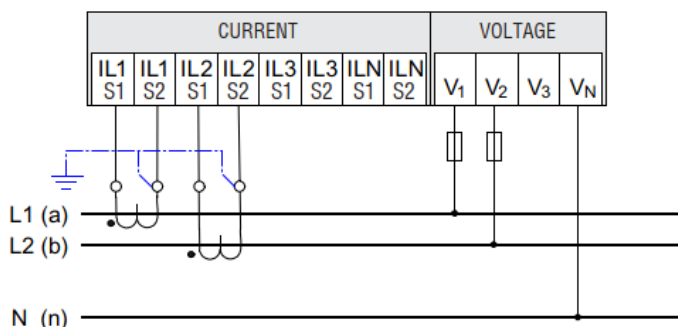

(9) Single-phase measuring, two conductors, with voltage transformers, with three current transformer.

**Connection type 3X1PH**

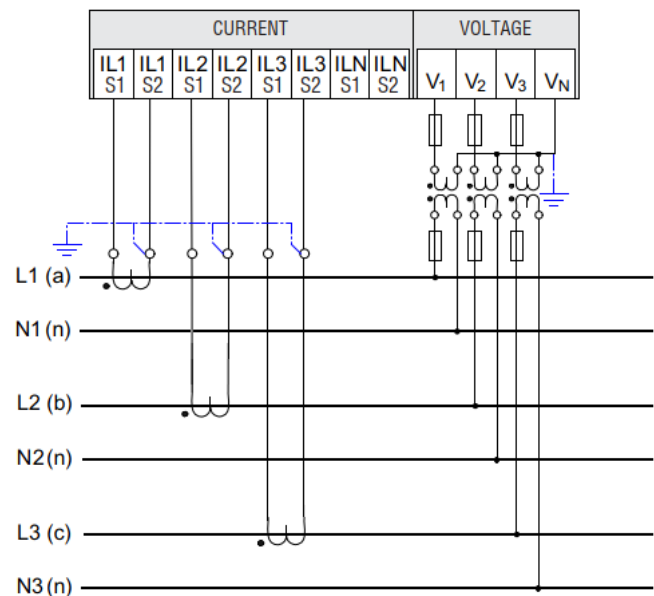

(10) Three-phase measuring, with two voltage transformers and with three current transformer.

**Connection type ARON**

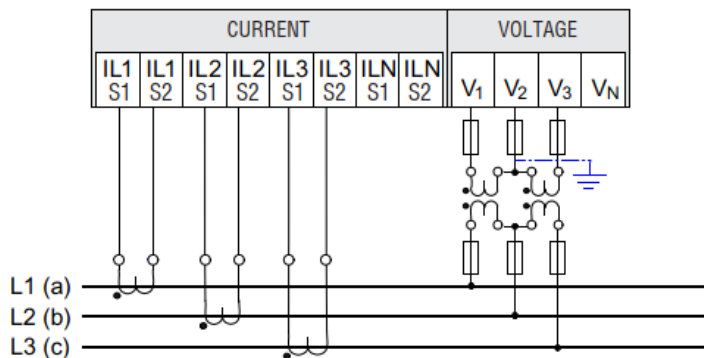

(11) Single-phase measuring, with three voltage transformers, with two current transformer.

12) Three-phase measuring, with three voltage transformers and with two current transformer.

**Connection type ARON**

**Connection type ARON**

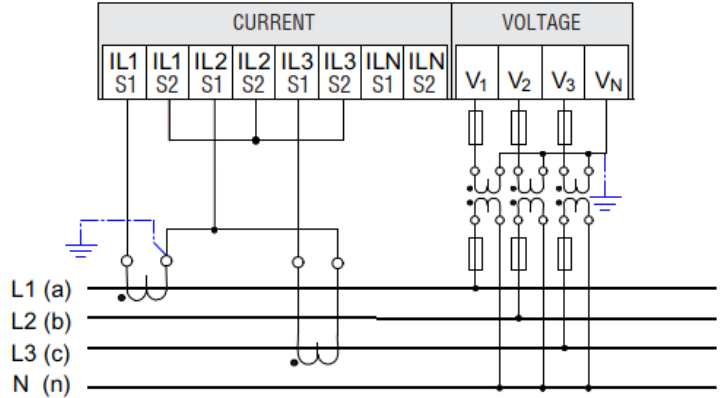
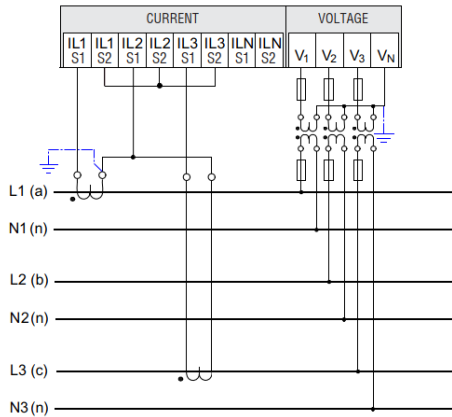

**Check proper connection**

Observe the relevant standards and regulations for installation and connection as well as the operating manual of the respective device.

**Switching on**

To switch the device on, follow the steps below:

1. Connect the supply voltage.
2. Set the language.
3. Set the wiring connection.
4. Set the CT transformer primary.
5. Set the CT transformer secondary.
6. Set the CT-N transformer primary.
7. Set the CT-N transformer secondary.
8. Set the VT transformer primary.
9. Set the VT transformer secondary.
10. Set date and time

**Keys functionality**

**Directional Keys (Up - Down - Left - Right)**

The arrow keys are used to change pages in Metering, Energy, Graphics, Information and Setup. In the next chapters are shown the maps of how to move between the pages. In the same way the directional keys allow you to move and select the items in the Menu. The **Up** and **Down** keys are used to increment and decrement or simply change the value set in the Setup pages. Pressing the **Up** and **Down** keys at the same time returns to the default page from the current page. By pressing the **Left** and **Right** keys at the same time, you can define the **default** page. The page title will change color and the home icon will appear next to the text to confirm the new default page.

**ENTER key**

The **Enter** key on the pages of Metering, Energy, Graphics, Information and Setup, allows you to enter the Menu and confirm the selected item. In the Setup you can select the parameter to be modified and confirm the new value.

**ESC key**

This button is used for:

- exit without confirming the change in progress;
- return to the display page after entering any page of the instrument setup;
- return to the top level of the menu if multiple levels are open;

**Power factor rules**

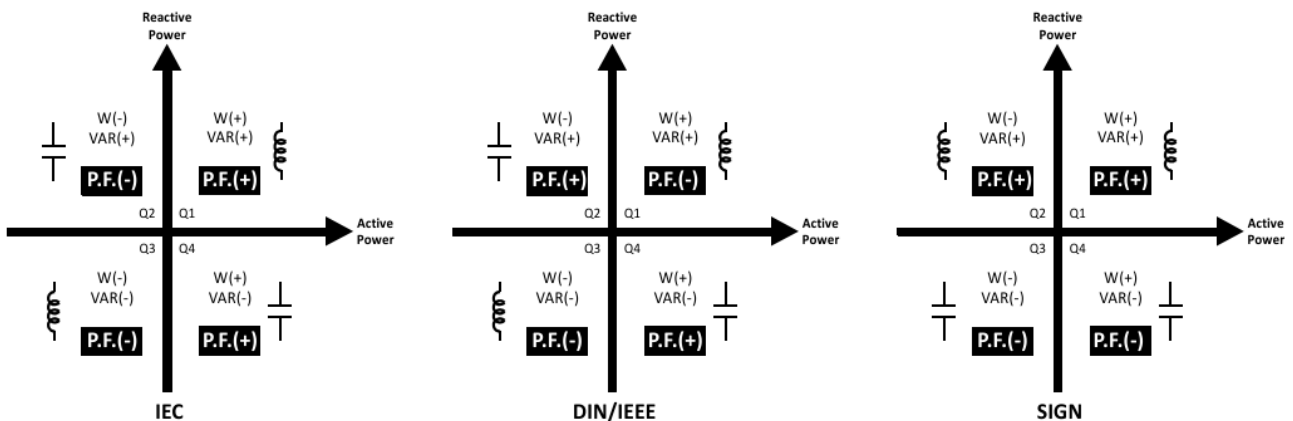

### Harmonic analysis page (optional)

- The EMS-96 provides the harmonic analysis up to 21<sup>st</sup> order of the following measurements:
  - phase-to-phase voltages
  - phase-to-neutral voltages
  - currents
- For each of these measurements, there is a display page that graphically represents the harmonic content using a bar graph.
- Every column is related to one harmonic order, even and odd.
- Every display page is related to each phase L1, L2, L3.
- The value of the harmonic content is expressed as a percentage.
- It is possible to show the harmonic content in numeric format, pressing ► button.
- The vertical scale of the graph is automatically selected, depending on the column with the highest value.

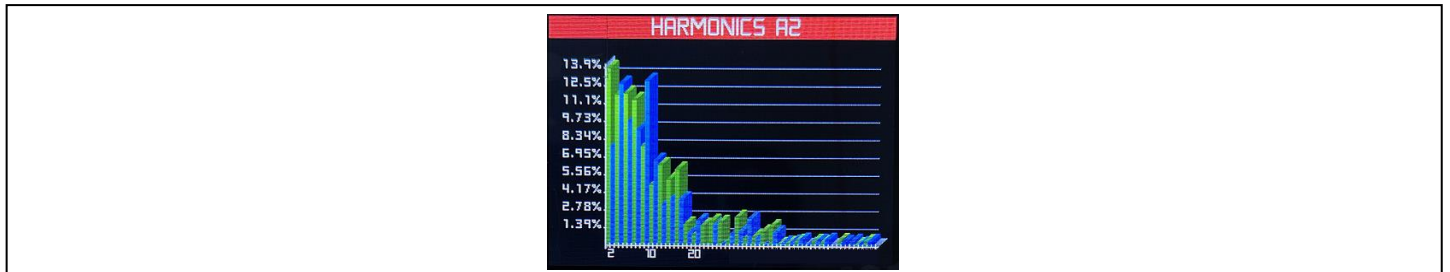

### Trend graph page

- The trend graph page allows to show the changes in the time of phase-to-neutral voltages and currents. This functionality provides a real-time snapshot of network condition.
- It's possible to see, on the graph, the history of last 60 values of the measurement, each correspondent to every 2 seconds of instantaneous value.
- When the maximum storing capacity is exceeded, the newest data will overwrite the oldest, so that the most recent data is always shown.
- The vertical full-scale is calculated automatically.

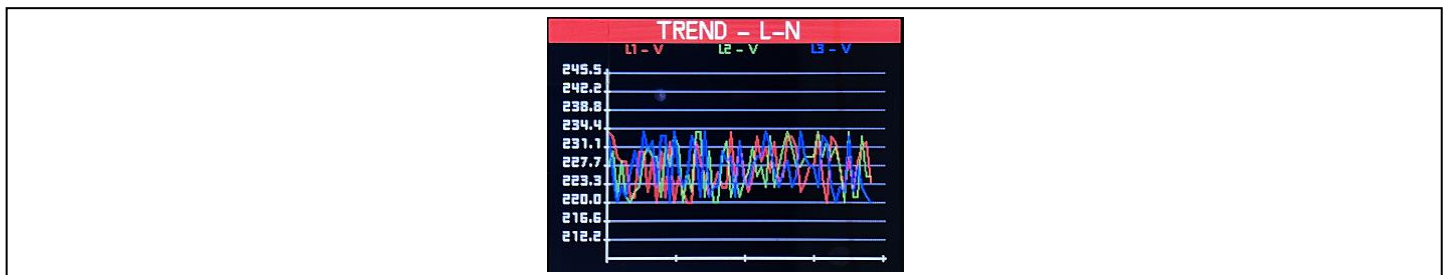

### Power bar-graph page

- This page graphically view the daily power consumption (24 hours) of the active and reactive powers read by the EMA-D6.
- It's possible to see one day at a time, selecting it by clicking ► button.
- The vertical full-scale is calculated automatically, depending on the column with the highest value.

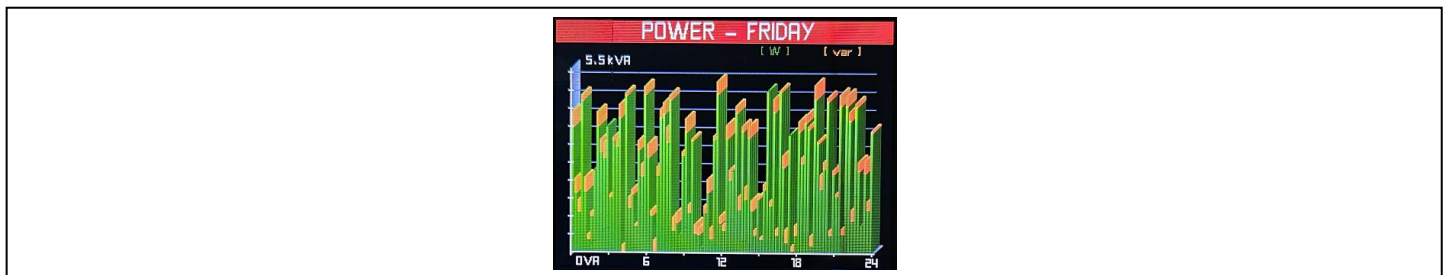

### Phasors page

- The phasor diagram shows voltages and currents in relation to each other.
- The currents are depicted within the inner circle while the voltages are shown within the outer circle.
- It's possible to see, on the this page, the angle value between the phasors.

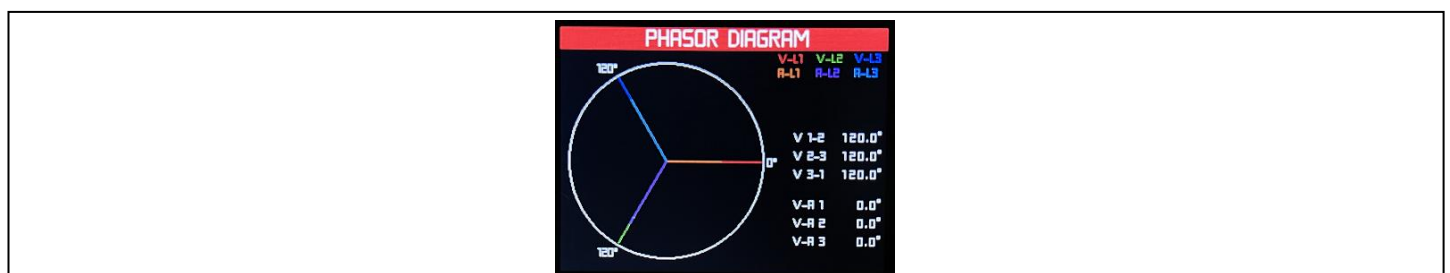

**Energy bar-graph page**

- These pages graphically view the daily, weekly, monthly and yearly energy counters consumption of the active (IN and OUT) and reactive (IN and OUT) energy read by the EMA-D6. For every graph, the unit displays the 4 total counters (Wh IN, Wh OUT, VARh IN, VARh OUT).
- It's possible to see one day at a time, selecting it by clicking ► button.
- It's possible to clear completely through the dedicated command in the RESET menu.
- If a count is not available, then some empty spaces are shown.

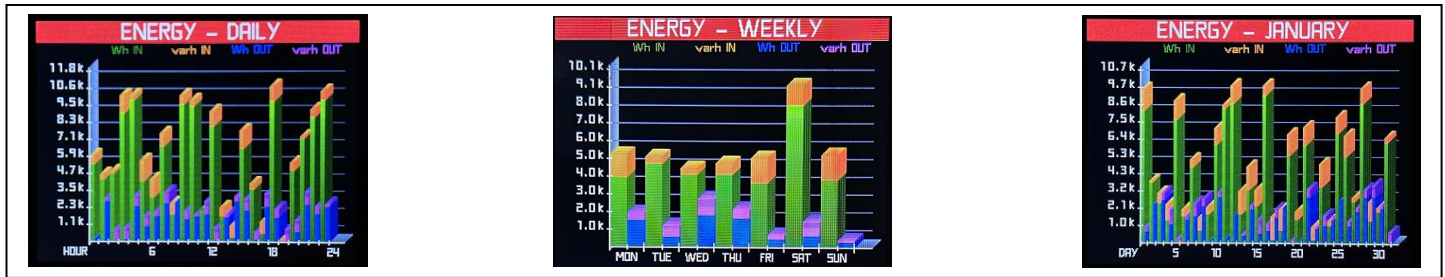

**Setpoint thresholds**

- The setpoint thresholds are internal variables whose status depends on the out of limits of one particular measurement set by user among all those measured (example: active power higher than 40 kW).
- For each setpoint, there are 2 thresholds (upper and lower). The upper threshold must always be set to a value higher than the lower threshold.
- For every setpoint is possible to set a delay when alarms is triggered on and off.
- When specific conditions are met, alarms is turned on or off. Triggering of alarms can be registered in the devices notifications log, in the events section, increasing timer. In addition to that, they can be set up to control digital outputs of the device.
- There are two types of setpoints available on EMA-D6: simple setpoint and "complex" condition to a setpoint using Boolean logic variables (AND, OR).
- For setpoint thresholds programming and definition refer to setup menu SETPOINT chapter.

For more information on how the meter handles the setpoint-driven alarms, refer to the figure below.

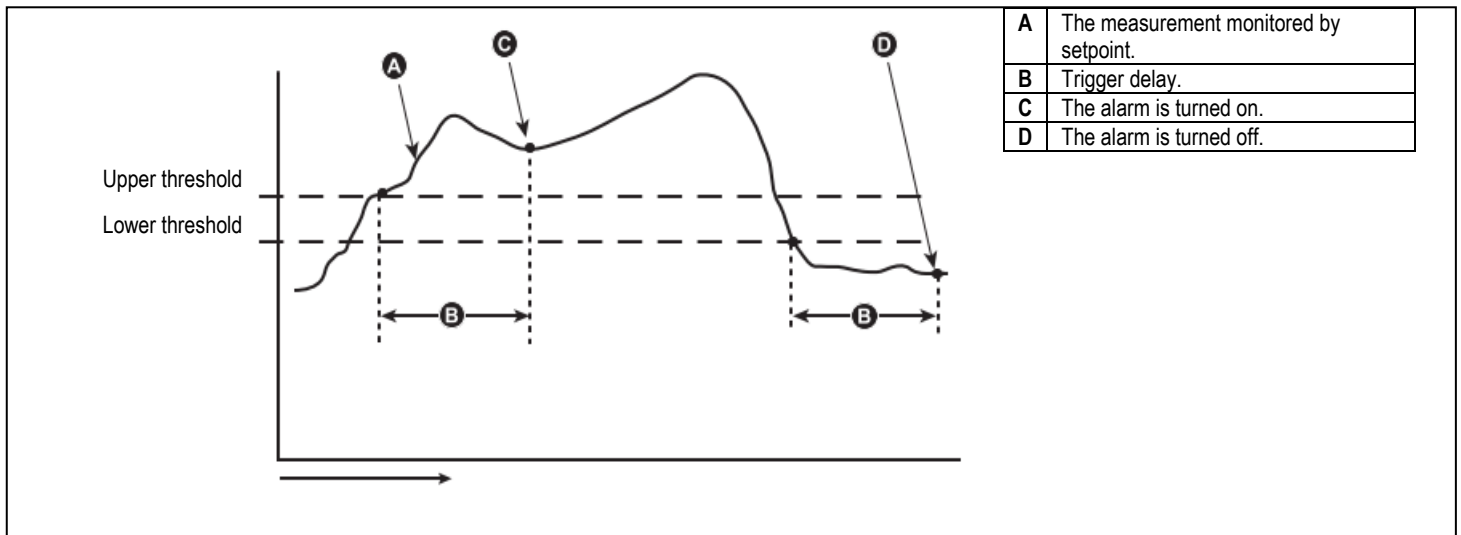

**Data logger function**

- The data logger allows to store at regular interval up to 14 variables chosen freely among the multimer measures.
- Every record is marked with a timestamp taken from the internal real-time clock. The minimum sampling period (distance between two records) is of 1 second.
- Considering the amount of memory, the number of variables to be stored and sampling period, the unit indicates the time that must elapse before the memory is completely filled.
- The recording can be continuous (driven only by regular time intervals) or conditional (between a specified date/time range), driven only by the status of the internal variables (setpoint) or digital input status.
- When the memory is full, the user can choose to stop the recording (End Memory mode) or to continue overwriting the oldest records (FIFO mode).
- The display page dedicated to the data logger info (MENU - INFO - LOG SUMMARY) shows all the fundamental information: number of records, sampling, available free memory, residual time before the memory if filled (when working in End Memory mode).

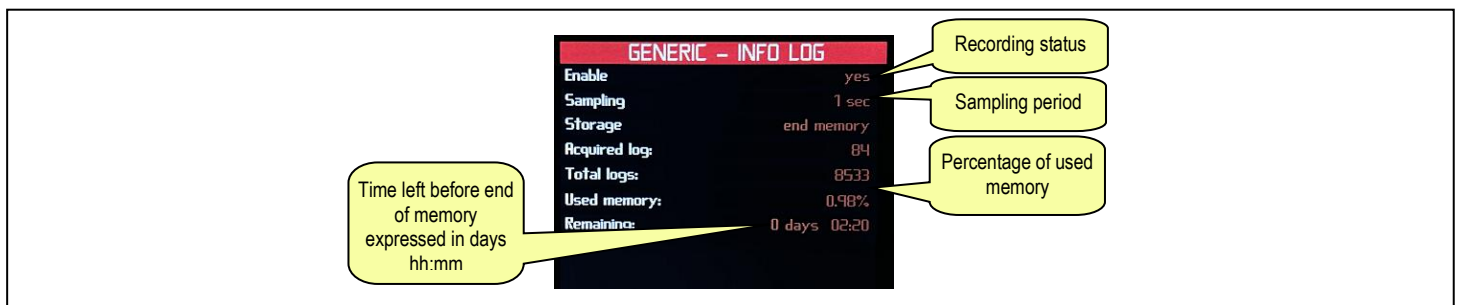

## Configuration mode menu trees

The following diagram will help you navigate through the menus.

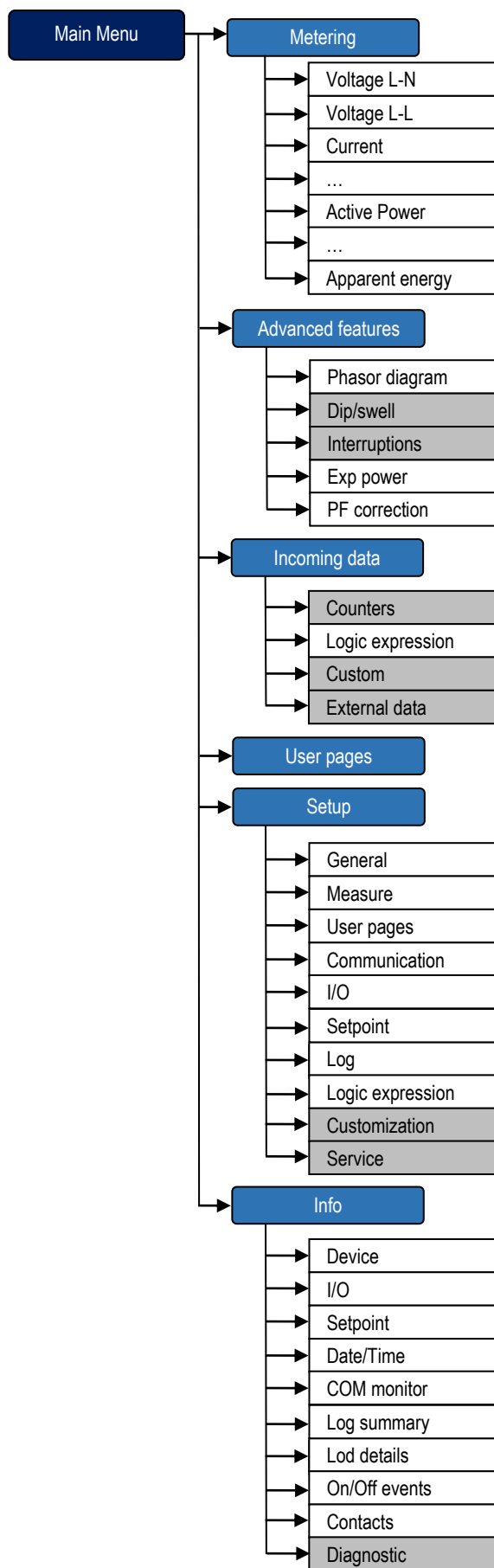

Note: if the option is not present, the menu will be disable (grey color)

## Visualization

The analyzer allows to view the measures in different formats:

### Numbers (measures and energy section)

By pressing the up and down keys it is possible to view the instantaneous measures (voltages, currents, powers etc.) while, where they are available, with the right and left keys it is possible to switch to the minimum / maximum relative categories, absolute minimum / maximum, average and maximum demand.

**Note:** The first page shown at power-up is "Phase voltages" (default page). You can change this setting by go to the desired page and press the left and right keys simultaneously.

### Graphics

With the directional keys it is possible to move to view different types of information from the phasor page (to verify during installation that everything is correct).

### User Pages

In these special pages the keys on the lower part of the instrument are not used to move between the pages present but each of them is associated with a unique page. This page is completely configurable from the text of the title to the text of the individual keys and also in the number and type of quantities displayed. The indication of the page (text key) has a different color than the others.

CURRENTS		
ΣA	38.62	A
A1	10.53	A
A2	15.67	A
A3	12.42	A
L-N	L-L	A
P.F	W	VAr

### Customization of the user page

Setup → User Pages → Titles: edit page title.

Setup → User Pages → Composition: changing the displayed measurement of the page.

Settings → User pages → Key text: change the texts corresponding to the 6 keys.

**Note:** When a User Page is displayed, to open the main menu, press the  key for at least 4 seconds and release.

## Measurements

	Instant	Relative min & max	Absolute min & max	AVG	Max demand	Graphics
Voltages L-N	•	•	•	•	•	•
Voltages L-L	•	•	•			
Currents	•	•	•	•	•	•
PF	•	•	•	•	•	•
Cos Phi	•	•	•	•	•	
Tan Phi	•	•	•	•	•	
Crest factor	•	•	•			
Active power	•	•	•	•	•	•
Reactive power	•	•	•	•	•	•
Apparent power	•	•	•	•	•	•
Frequency	•	•	•	•		
THD V & A	•					
Harmonics	•					•
Counters	•					
Expected power	•					

## Parameters table

Below are listed all the programming parameters. For each parameter are indicated the setting range, the factory default, as well as a description of the function.

### GENERAL menu

PASSWORD		Range	Default
1	Level 1 [visualization]	0 ÷ 999999999	0
2	Level 2 [setup]	0 ÷ 999999999	0
3	Validity key [minutes]	1 ÷ 60	5
4	Keys protect	YES-NO	NO
5	Communication protect	YES-NO	NO
6	Enable options	0 ÷ 999999999	0

1 - If set to 0 (OFF), password management is disabled and access to the visualization is free. If active, to gain access you must first enter the relative numeric access code.

2 - If set to 0 (OFF), password management is disabled and access to the settings is free. If active, to gain access you must first enter the relative numeric access code.

3 - Time of free access to the settings after access with password.

4 - If active, the keys are disabled. To gain access you must first enter the relative numeric access code (see point 1).

5 - If active, to change the setup (from communication interface) send the password command before others commands.

6 - Numeric code to enable software options.

RESET		Description
1	Global	All device parameters are resetted to factory default value.
2	Setup to default	All setup parameters are resetted to factory default value.
3	All energies	Clears total and tariff energy meters.
4	TB energies	Clears tariff energy meters.
5	Counters	Clears counters.
6	TB counters	Clears tariff counters.
7	MIN-MAX	Reset of MAX and MIN peaks of all readings.
8	Max demand	Reset of Max Demand of all readings.
9	Energies graphics	Clears the energy graphics.
10	Setpoint log	Clears the alarm log events.
11	All log	Clears the log memory (both events and measurements log).
12	ON / OFF events	Clears the power supply switch ON/OFF events.
13	Manual reset SP-DO	Manual command in order to reset the digital output of the alarm setpoint.
14	DIP / SWELL	Clears the DIP / SWELL log memory.
15	Max AI indicators	Clears the MAX of analogic indicator of measurements.
16	Setpoint hour counter	

### DATE AND TIME

- The EMS-96 manages the date and time, that is used for the storage events and for time-related functions. The EMS-96 is equipped with a module with RTC (real-time clock), then the time and date are kept updated even without auxiliary power supply, for a maximum of about 1 week.

UTILITY		Default	Range
1	Language	English	English Italiano Deutsche Polski Francais Svenska Espanol
2	Theme	Blue-Black	Blue-Black...White Red-Black...White Yellow-Black...White Grey-Black...White
3	Text dimension	Standard	Standard-Big
4	Set-point alert	OFF	ON-OFF-First Out
5	Protocol	Standard	Standard-Previous
6	Page selection	Standard	Standard-Smart
7	Startup RTC check	YES	YES-NO

4 - When it is activated the display page switches automatically on the alarm page, and the alarm is shown with the Warning icon.

5 - When it is selected the "previous", the communication protocol switches on the old EMS-96.

6 - If set to smart, in each measurement page, there is a part of display composed by icons which they allow to access several sub-pages simply selecting the correspondent icon.

7 - If set to YES, at each start, the instrument will check the correct functioning of the RTC clock.

DISPLAY		UoM	Default	Range
1	Brightness	-	15	1÷15
2	Default page return	min	5	5-10-15-20-30-60-NO
3	Stand-by	-	YES	NO-YES
4	Stand-by time	min	10	1÷60
5	Refresh	ms	4	1÷60
6	Left LED	-	Metrological Wh	Metrological Wh-setpoint
7	Right LED	-	Metrological VARh	Metrological VARh-status-com monitor
8	Pulse LED weight	-	0.1	0.1-1-10

1 - Set up the level of brightness display.

2 - If set to NO the display will remain in the page where the user left it. If set to a time delay, after that time the display page goes back to page set as default.

4 - Set up the time after that the display will switch off. The lifetime of the graphical display depends on its brightness and stand-by time. It is highly recommended to limit the brightness level of the display in order to ensure a longer lifetime of the device.

5 - Display update time. **Note: 1 = 250 ms**

8 - Quantity of energy for each pulse referred to the front LEDs.

GRAPHICS		UoM	Default	Range
1	Clear MAX bar	-	NO	NO-YES
2	Max V	%	100	0-100
3	Max A	%	100	0-100
4	Max W	%	100	0-100
5	Limit W	%	80	0-100
6	Max Var	%	100	0-100
7	Limit Var	%	80	0-100
8	Show harmonics	-	ALL	15 <sup>th</sup> -ALL

1 - Clears of the max for bar graph.

2, 3, 4, 6 - Set the max for bar graph of the associated measure.

8 - Number of the viewing harmonics. If set to ALL, the display show up the order 21<sup>th</sup>

#### MEASURE menu

TRANSFORM RATIO		UoM	Default	Range
1	CT primary	A	1	1÷400000
2	CT secondary	A	1	1÷400000
3	CT-N primary	A	1	1÷400000
4	CT-N secondary	A	1	1÷400000
5	VT primary	V	1	1÷400000
6	VT secondary	V	1	1÷400000

**Note: If Rogowski coils are used, it is not needed to set any transformation ratio.**

1 - CT primary winding rated current.

2 - CT secondary winding rated current.

3 - CT Neutral primary winding rated current.

4 - CT Neutral secondary winding rated current.

5 - VT primary winding rated current.

6 - VT secondary winding rated current.

TIME WINDOW		UoM	Default	Range
1	Dimension	min	15	1-2-3-5-6-10-12-15-20-30-60
2	Type	-	Shifting	Shifting-Fixed

1 - Selection the integration time interval.

2 - Selection of average reading calculation mode:

**Shifting** = The instantaneous values are integrated for a period.

**Fixed** = Readings are integrated for a fixed rated. Every time the integration time elapses, the average value is updated with the result of the last integration.

FREQUENCY		UoM	Default	Range
1	Fundamental	Hz	50	50-60
2	Zero-crossing	-	default	low-medium-high

1 - Rated frequency of the line. Possible nominal frequency values: 50 Hz or 60 Hz.

2 - Zero-crossing detection for frequency measurement. Zero crossing detection with a *filter* is a common method used to estimate a signal frequency or period when the signal is affected by.

DIP / SWELL		UoM	Default	Range
1	DIP threshold	mV	190000	10÷10000000
2	DIP cycles	cycles	250	1÷10000
3	SWELL threshold	mV	270000	10÷10000000
4	SWELL cycles	cycles	250	1÷10000
5	Interruption threshold	mV	205000	10000÷200000000
6	Interruption hysteresis	mV	275000	10000÷200000000
7	Storage	-	End memory	FIFO End memory

1 - Threshold active when the voltage is lower than value set.

2 - The duration of voltage dip. **Note: 1 = 10 ms**

3 - Threshold active when the voltage is higher than value set.

4 - The duration of swell over-voltages. **Note: 1 = 10 ms**

5 - Voltage interruption begins when the RMS value falls below this threshold. A voltage interruption ends when the voltage is equal to, or greater than, interruption threshold plus the hysteresis.

6 - Hysteresis delay on voltage interruption.

7 - When the memory is full, the user can choose to stop the recording (end memory) or to continue overwriting the oldest records (FIFO).

WIRING / CONVENTION		UoM	Default	Range
1	Wiring	-	3 phase (4 or 3 wires)	3 phase (4 or 3 wires) ARON Balanced 3 phase 3 phase multiload balanced Single phase Single phase multiload Multiload single phase Two-phase (3 wires)
2	4th input current	-	Measured	Computed-Measured Differential-Differential filter
3	PF convention	-	SIGN	SIGN-IEC-IEEE
4	Setpoint timing	s	1	0.1-1
5	Rogowski full scale	mV	350	175-350-700
6	Filter mV (no KCT)	mV	10000	2000÷20000
7	Filter µA (no KCT)	µA	300	300÷4000000

1 - Set this parameter according to the used wiring diagram. See wiring diagrams section on the manual.

2 - The fourth current input channel (I4) is used to measure the current on the neutral line or differential current. If the CT for the neutral wire is not available, the I4 input can be calculated from the phase currents.

3 - The meter shows positive or negative power factor according to selected standard.

4 - Set the setpoint intervention time.

5 - Rogowski Coil CT selectable full scale.

6 - Set the cut-off to reduce voltage measurement noise.

7 - Set the cut-off to reduce current measurement noise.

TYPE / MODALITY		UoM	Default	Range
1	Unit of measure	-	mV-mA-W-kWh	mV-mA-mW-Wh mV-mA-W-kWh V-A-kW-MWh
2	Modality	-	Bidirectional	Bidirectional-Monodirectional
3	Compute I diff (I1+I2+I3+IN)	-	NO	YES-NO
4	THD avg	samples	1	1÷10

1 - Set this parameter according to the measurements .

2 - If set bidirectional, the energy meters shows imported/exported active energy, inductive/capacitive reactive energy.

3 - If set YES, the calculation for differential current will be considering I1+I2+I3+IN.

4 - Set the sample for THD average calculation.

## ENERGY menu

PRELOADED		UoM	Default	Range
1	Wh+ L1	0.1 k	0	0÷1000000000
2	Wh- L1	0.1 k	0	0÷1000000000
3	VArh+ L1	0.1 k	0	0÷1000000000
4	VArh- L1	0.1 k	0	0÷1000000000
5	Vah L1	0.1 k	0	0÷1000000000
6	Wh+ L2	0.1 k	0	0÷1000000000
7	Wh- L2	0.1 k	0	0÷1000000000
8	VArh+ L2	0.1 k	0	0÷1000000000
9	VArh- L2	0.1 k	0	0÷1000000000
10	Vah L2	0.1 k	0	0÷1000000000
11	Wh+ L3	0.1 k	0	0÷1000000000
12	Wh- L3	0.1 k	0	0÷1000000000
13	VArh+ L3	0.1 k	0	0÷1000000000
14	VArh- L3	0.1 k	0	0÷1000000000
15	Vah L3	0.1 k	0	0÷1000000000

1..5 - Set a value of energy meters (L1) for: active energy imported and exported, reactive energy inductive and capacitive, apparent energy.

6..10 - Set a value of energy meters (L2) for: active energy imported and exported, reactive energy inductive and capacitive, apparent energy.

11..15 - Set a value of energy meters (L3) for: active energy imported and exported, reactive energy inductive and capacitive, apparent energy.

TIMEBAND		UoM	Default	Range
1	Energy changing	-	From comm.	From comm.-From DI-Preset-From key
2	Energy TB	-	1	1÷16
3	Counter changing	-	From comm.	From comm.-From DI-Preset-From key
4	Counter TB	-	1	1÷16

1 - Set the energy meters tariff selection: from comm. (dedicated command via Modbus protocol), by the change in digital inputs (their binary combination selects the tariff as shown in table), preset (by daily, period plan), keys (by frontal keyboard).

2 - When energy timeband selection is made by keys, select among the 16 timebands.

3 - Set the counters selection: from comm. (dedicated command via Modbus protocol), by the change in digital inputs (their binary combination selects the tariff as shown in table), preset (by daily, period plan), keys (by frontal keyboard).

4 - When counter timeband selection is made by keys, select among the 16 timebands.

DIG. INPUT-4	DIG. INPUT-3	DIG. INPUT-2	DIG. INPUT-1	TIMEBAND
0	0	0	0	1
0	0	0	1	2
0	0	1	0	3
0	0	1	1	4
0	1	0	0	5
0	1	0	1	6
0	1	1	0	7
0	1	1	1	8
1	0	0	0	9
1	0	0	1	10
1	0	1	0	11
1	0	1	1	12
1	1	0	0	13
1	1	0	1	14
1	1	1	0	15
1	1	1	1	16

DAILY PLAN n (n=1..16)		UoM	Default	Range
1	Start hour	hour	0	0÷23
2	Start minute	min	0	0÷59
3	Timeband used	-	TB n	TB1..16

**NOTE: this menu is divided into 16 sections, for DAILY PLAN1..16. Each DAILY PLAN supports a maximum of 16 time segments.**

1 - Configuring the start hour.

2 - Configuring the start minute.

3 - Select among the 16 timebands.

PERIOD PLAN n (n=1..16)		UoM	Default	Range
1	Enable	-	NO	YES-NO
2	Start month	-	January	January..December
3	Start day	-	1	1÷31
4	End month	-	December	January..December
5	End day	-	31	1÷31
6	Monday	-	Daily plan 1	Daily plan 1..16
7	Tuesday	-	Daily plan 1	Daily plan 1..16
8	Wednesday	-	Daily plan 1	Daily plan 1..16
9	Thursday	-	Daily plan 1	Daily plan 1..16
10	Friday	-	Daily plan 1	Daily plan 1..16
11	Saturday	-	Daily plan 2	Daily plan 1..16
12	Sunday	-	Daily plan 3	Daily plan 1..16

**NOTE: this menu is divided into 16 sections, for PERIOD PLAN1..16.**

- 1 - Enables period plan.
- 2 - Configuring the start month.
- 3 - Configuring the start day.
- 4 - Configuring the end day.
- 5 - Configuring the end month.
- 6..12 - Weekdays selection of schedule mode among the 16 daily plans.

HOLIDAY n (n=1..48)		UoM	Default	Range
1	Month holiday	-	January	January..December
2	Day holiday	-	1	1÷ 31
3	Plan holiday	-	Daily plan 1	Daily plan 1..16

**NOTE: HOLIDAY menu supports a maximum of 48 holidays.**

- 1 - Configuring the month.
- 2 - Configuring the day.
- 3 - Selection of schedule mode among the 16 daily plans.

**USER PAGES menu**

PAGE TYPE		UoM	Default	Range
1	User page type	-	Instantaneous	Instantaneous Average Energies Setpoint

**NOTE: this menu is divided into 6 sections, for user pages PAG1..6**

- 1 - Set measurements category that will be shown in the frames of the user pages.

COMPOSITION PAGE		UoM	Default	Range
1	Row 1	-	OFF	OFF - (measurements)
2	Row 2	-	OFF	OFF - (measurements)
3	Row 3	-	OFF	OFF - (measurements)
4	Row 4	-	OFF	OFF - (measurements)
5	Row 5	-	OFF	OFF - (measurements)
6	Row 6	-	OFF	OFF - (measurements)

**NOTE: this menu is divided into 6 sections, for user pages PAG1..6**

- 1, 2, 3, 4, 5, 6 - Measurement that will be shown in the six rows of the user pages (according to the user page type selection).

TITLE PAGE		UoM	Default	Range
1	Title	-	TITLEn	(Text - 20 chars)

**NOTE: this menu is divided into 6 sections, for user pages PAG1..6**

- 1 - Title of the user page. Free text, 20 chars.

EDIT KEYS TEXT		UoM	Default	Range
1	Key 1	-	SYS	(Text - 20 chars)
2	Key 2	-	V	(Text - 20 chars)
3	Key 3	-	A	(Text - 20 chars)
4	Key 4	-	PF	(Text - 20 chars)
5	Key 5	-	W	(Text - 20 chars)
6	Key 6	-	var	(Text - 20 chars)

- 1, 2, 3, 4, 5, 6 - Short key on the bottom of the display to scroll through user pages. Free text, 20 chars.

## COMMUNICATION menu

COMn RS-485 (n=1..2) (COM2 optional)		UoM	Default	Range
1	Mode	-	Slave	Slave - Master - Gateway
2	Devices read	-	1	1÷20
3	Master timeout	ms	800	0÷10000
4	Scan rate	ms	1000	0÷10000
5	Serial node	-	1	1÷247
6	Serial speed	-	38400	4800...115200
7	Stop bits	-	1	1-2
8	Data format	-	8 bit, no parity	8 bit, no parity 8bit, odd 8 bit, even
9	MIN response delay	ms	10	5÷100

**NOTE: this menu is divided into 2 sections, for comm channels COM1..2 (COM2 optional)**

1 - Set the communication function. **Slave** = Awaits connection from a remote master. **Master** = Establishes a connection to the remote devices. **Gateway** = Activating this function it's possible to use an EMA-D6 with both an Ethernet port and RS-485 port, that works as Modbus TCP bridge over other devices equipped with RS-485 only, in order to achieve a more economic configuration (only one Ethernet port).

2 - When EMA-D6 will be configured as Master, set the number of devices connected to RS-485 port.

3 - When EMA-D6 will be configured as Master, set the timeout period on RS-485 port to collect the data.

4 - When EMA-D6 will be configured as Master, set the transmission polling time to collect the data.

5 - Serial address (node number) for the communication protocol. EMA-D6 will be configured as Slave.

6 - Serial communication speed.

7 - Number of stop bits.

8 - Data format.

9 - Set the response delay period on RS-485 port when EMA-D6 will be configured as Slave.

ETHERNET (optional)		UoM	Default	Range
1	IP Address	-	10.0.0.100	000.000.000.000-255.255.255.255
2	Subnet mask	-	255.0.0.0	000.000.000.000-255.255.255.255
3	IP gateway	-	10.0.0.1	000.000.000.000-255.255.255.255
4	TCP port (1)	-	502	0÷65535
5	TCP port (2)	-	503	0÷65535
6	DHCP	-	OFF	OFF-ON
7	TCP timeout	s	4200	10÷100000

**NOTE: this menu is available only with ETH-MOD (connector above of the enclosure).**

PROFIBUS (optional)		UoM	Default	Range
1	Profibus node	-	1	1-126

PROFIBUS FRAME		UoM	Default	Range
1	Group 1...28	-	Instantaneous	Instantaneous Harmonic V1...V3 Harmonic I1...I3 Energies Energy TB1...TB16
2	Item 1...28	-	-	(Measurements)

**NOTE: this menu is divided into 28 sections.**

**Set the measurements packet transfer from master and slave.**

1 - Set measurements category that will be compose in the Profibus DP frames.

2 - Measurement that will be compose the Profibus DP frames (according to the Group type selection).

MBUS (optional)		UoM	Default	Range
1	Node MBUS	-	1	1÷247
2	MBUS speed	-	2400	300÷38400
3	Stop bits	-	1	1-2
4	Data format	-	8 bit, even	8 bit, no parity 8bit, odd 8 bit, even
5	MIN response delay	ms	35	5÷100

1 - MBUS address (node number) for the communication protocol.

2 - MBUS communication speed.

3 - Number of stop bits.

4 - Data format.

5 - Set the response delay period on MBUS port.

MBUS FRAME A		UoM	Default	Range
1	Group 1...18	-	Instantaneous	Instantaneous Average Energies Energy TB1...TB16
2	Item 1...18	-	-	(Measurements)

NOTE: this menu is divided into 18 sections.

Set the measurements packet transfer (Frame A) from master and slave.

- 1 - Set measurements category that will be compose in the MBUS frame A.
- 2 - Measurement that will be compose the MBUS frame A (according to the Group type selection).

MBUS FRAME B		UoM	Default	Range
1	Group 1...18	-	Instantaneous	Instantaneous Average Energies Energy TB1...TB16
2	Item 1...18	-	-	(Measurements)

NOTE: this menu is divided into 18 sections.

Set the measurements packet transfer (Frame B) from master and slave.

- 1 - Set measurements category that will be compose in the MBUS frame B.
- 2 - Measurement that will be compose the MBUS frame B (according to the Group type selection).

MBUS FRAME A default	Group	Measurement
1	Energies	ΣWh IN
2	Energies	ΣVArh IN
3	Instantaneous	W
4...18	Not used	Not used

MBUS FRAME B default	Group	Measurement
1	Instantaneous	V1
2	Instantaneous	V2
3	Instantaneous	V3
4	Instantaneous	A1
5	Instantaneous	A2
6	Instantaneous	A3
7...18	Not used	Not used

WEB (optional)		UoM	Default	Range
1	IP Address	-	10.0.0.100	000.000.000.000-255.255.255.255
2	Subnet mask	-	255.0.0.0	000.000.000.000-255.255.255.255
3	IP gateway	-	10.0.0.1	000.000.000.000-255.255.255.255
4	TCP port	-	502	0÷65535

NOTE: this menu is available only with ETH-WEB (connector on the back of the enclosure).

SLAVE TYPE (1...20)	UoM	Default	Range
1	Slave node 1...20	-	-
			TTC-V, EMT-1C, CTT-4, CTT-8, HRI, EMM-h, EMT-4S, EMS-96, EMA-90N, RI-SM, DVH 5.., EMM-dc, EMM-4L, Comp D2, EML-16, EMU-3ea, MR-R8, RI-R44, MR-AO, EMA-V1

NOTE: this menu is divided into 20 sections (max Slave number).

Set it only if the RS-485 operation mode is Master mode (see COM RS-485 settings menu).

- 1 - Set of the type of slave connected, which the EMS-96 will collect the measurements.

## DIGITAL OUTPUT menu

DIGITAL OUTPUT (OUTn, n=1..8)		UoM	Default	Range
1	Status	-	0	0-1
2	Level	-	Normally open	Normally open - Normally closed
3	Mode	-	Status	Status - Pulse - Setpoint Status memory - Pulse after write
4	Pulse weight (1 = 0.1k)	-	1	1÷10000
5	Pulse period	ms	500	60÷10000
6	Source associated	-	WhIN	Wh IN,Wh OUT,VARh IN,VARrh OUT,VAh Wh IN L1,Wh OUT L1, VARh IN L1,VARrh OUT L1, VAh L1 Wh IN L2,Wh OUT L2, VARh IN L2,VARrh OUT L2, VAh L2 Wh IN L3,Wh OUT L3, VARh IN L3,VARrh OUT L3, VAh L3

**NOTE: this menu is divided into 8 sections, for digital outputs OUT1..8 (OUT1,2 standard - OUT3,4,5,6,7,8 optional)**

1 - If set to 1, test to activate the output.

2 - Normal status of the output. Allows reversing the logic of the output function.

3 - Function of the output:

**STATUS** - Output linked to the status of the programmed variable.

**PULSE** - Energy count pulses.

**SETPOINT** - Allows connecting the status of an output to the status of a limit threshold of setpoint.

**STATUS MEMORY** - Defines if the status of an output remains at power on.

**PULSE AFTER WRITE** - Allows connecting the status of an output to the write command Modbus.

4 - Quantity of energy (only if set Mode = Pulse or Pulse after write).

5 - Pulse duration (only if set Mode = Pulse or Pulse after write).

6 - Type of energy to which the pulse is linked to (only if set Mode = Pulse or Pulse after write).

## DIGITAL INPUTS menu

DIGITAL INPUT (DI n, n=1..4)		UoM	Default	Range
1	Mode	-	Status	Status - Counter - Change energy TB Change counter TB - Change E+C TB External trigger - Reset SP-DO Inhibition M - Inhibition M+D
2	Multiplier	-	1	1÷100000
3	Divisor	-	1	1÷100000
4	Level action	-	Normally open	Normally open - Normally closed
5	SP-DO reset	-	OFF	OFF-Setpoint 1...Setpoint 32
6	Unit	-	-	(Text - 20 char)
7	Name	-	DI n	(Text - 20 char)

**NOTE: this menu is divided into 4 sections, for digital inputs DI1..4**

1 - Function of the input:

**Status** - Signal that generates the activation of the input.

**Counter** - Signal that causes the increment of the counter.

**Change energy TB** - Energy Timeband selection. See Energy timeband chapter.

**Change counter TB** - Counter Timeband selection. See Energy timeband chapter.

**Change energy and counter TB** - Energy and Counter Timeband selection. See Energy timeband chapter.

**External trigger** - When this input is activated (triggered), the correspondent command is executed.

**Reset SP-DO** - When this input is activated (triggered), the correspondent setpoint reset is executed.

**Inhibition M** - When this input is activated, the measurement will be blocked.

**Inhibition M+D** - When this input is activated, the measurement and viewing will be blocked.

2 - Multiplying factor. If digital input is using as input pulses counter, the pulse counter is multiplied by this coefficient.

3 - Dividing factor. If digital input is using as input pulses counter, the pulse counter is divided by this coefficient.

4 - Status on activation of the input. Allows reversing the logic of the input function.

5 - When digital input is using as SP-DO reset, select the number of setpoint to reset.

6 - Description of digital input. Free text 20 characters. If digital input is using as input pulses counter.

7 - Unit of measure of digital input. Free text 20 characters. If digital input is using as input pulses counter.

## ANALOG OUTPUT menu

Analog Output (AO <sub>n</sub> , n=1..4)		Default	Range
1	Output type	0...20mA	0...20mA 4...20mA -10...10V (only with V,I option) -5...5V (only with V,I option) 0...10V (only with V,I option) 0...5V (only with V,I option)
2	Source	Internal	Internal - (Node 01÷20)
3	Group	Instantaneous	Instantaneous Average Energies Digital input Counters Logical function Energy TB1...TB16
4	Item	-	OFF - (measures)
5	Higher threshold value	0	-999999 ÷ +999999
6	Higher threshold unit	-	Unit measure of selected measurement
7	Lower threshold value	0	-999999 ÷ +999999
8	Lower threshold unit	-	Unit measure of selected measurement

**NOTE: this menu is divided into 4 sections, for analog outputs AO1..4**

1 - Defines the type of the analog sensor connected to analog output.

2 - Electrical parameter that controls the value of analog output:

**INTERNAL** - Measures provide from device.

**NODE 01÷20** - Measures provide from external device. **Set it only if the RS-485 operation mode is Master mode (see COM RS-485 settings menu).**

3 - Measurements group:

**INSTANTANEOUS**: Actual instantaneous values of reading.

**AVERAGE**: Time-integrated value of reading. Allows showing measurements with slow variations.

**ENERGIES**: Output linked to energy meters.

**DIGITAL INPUT**: Output linked to the status of a digital input.

**COUNTERS**: Output linked to generic counters.

**LOGICAL FUNTION**: Output linked to the status of the programmed variable.

**ENERGY TB1...TB16**: Output linked to energy tariffs.

4 - Select the measurement from the selected group.

5 - Used to define the upper threshold of the measurement.

6 - Select the unit measure for the upper threshold.

7 - Used to define the lower threshold of the measurement.

8 - Select the unit measure for the lower threshold.

## SETPOINT menu

SETPOINT (SP <sub>n</sub> , n=1..32)		UoM	Default	Range
1	Enable	-	OFF	OFF-ON
2	Source	-	Internal measures	Internal measures-(measures node 1-20)
3	Group	-	Instantaneous	Instantaneous-Average-Energies-Digital input-Counter-Analog input-Logic function-Energy TB1..16-Harmonics VL1..VL3-Harmonics IL1..IL3-Diagnostic
4	Item	-	-	OFF-(measures)
5	High threshold	-	0	-99999999 - +99999999
6	High threshold unit	-	-	(Unit of measures)
7	Low threshold	-	0	-99999999 - +99999999
8	Low threshold unit	-	-	(Unit of measures)
9	Activation delay	s	1	0-100000
10	Deactivation delay	s	1	0-100000
11	Hysteresis	%	0	0-100
12	Logic operation over	-	OFF	OFF-OR-AND
13	Logic operation entry	-	OFF	OFF-OR-AND
14	Operands 1-16	-	OFF	OFF-Setpoint 1...Setpoint 16
15	Operands 16-32	-	OFF	OFF-Setpoint 17...Setpoint 32
16	Action over	-	OFF	OFF-Save event-DO change-Increase event-Increase timer-Work hour-Pulse DO
17	Action entry	-	OFF	OFF-Save event-DO change
18	DO used	-	OFF	DO1..8-EXT DO1..24

**NOTE: this menu is divided into 32 sections, for alarm setpoints SP1..32**

- 1 - If set to ON, the setpoint alarm is enabled.
- 2 - Measurement source that generates the alarm. Internal measures or measures referred to the external devices (when EMA-D6 will be configured as Master RS-485).
- 3 - Measurement group that generates the alarm.
- 4 - Define which measurement of the device must be compared with limits.
- 5 - Used to define the upper threshold.
- 6 - Used to define the unit of measure of the upper threshold.
- 7 - Used to define the lower threshold.
- 8 - Used to define the unit of measure of the lower threshold.
- 9 - Alarm delay on upper threshold.
- 10 - Alarm delay on lower threshold.
- 11 - Hysteresis for the previous thresholds.
- 12 - Logic operation between operands for the upper threshold.
- 13 - Logic operation between operands for the lower threshold.
- 14, 15 - Define which setpoint used as operands for the previous thresholds.
- 16 - Alarm notification:  
**SAVE EVENT** - Log of alarm inside events list.  
**DO CHANGE** - When the alarm is tripped, the correspondent digital output is triggered.  
**INCREASE EVENT** - Increase the number of events above the alarm upper threshold.  
**INCREASE TIMER** - When the alarm is tripped, the correspondent timer (hh:mm:ss) is activated.  
**WORK HOUR** - Count of hours above the alarm upper threshold.  
**PULSE DO** - Pulse on digital output.
- 17 - Turn off alarm notification:  
**SAVE EVENT** - Log of turn off alarm inside events list.  
**DO CHANGE** - When the alarm is turning off, the correspondent digital output is triggered.
- 18 - If set DO change for the previous menu, define which digital output must be associated with an alarm.

SETPOINT (SPn, n=1..32)	UoM	Default	Range
1	Setpoint description	-	SETPOINT n (text - 20 char)

**NOTE: this menu is divided into 32 sections, for alarm setpoints SP1..32**

- 1 - Alphanumeric description of the setpoint. Free text 20 characters.

**LOG menu**

GENERIC	UoM	Default	Range
1	Enable	-	OFF-Always-Between date-Between hour- Between date and hour-Trigger
2	Sampling	-	15 min 1-2-3-5-6-10-12-15-20-30 sec 1-2-3-5-6-10-12-15-20-30-60 min End of day End of month
3	Storage	-	End memory / FIFO
4	Start month	-	January
5	Start day	-	1
6	Start hour	-	0
7	Start minute	-	0
8	End month	-	January
9	End day	-	1
10	End hour	-	0
11	End minute	-	0
12	Monday...Sunday	-	YES-NO
13	Trigger input	-	DI active HIGH DI active LOW Setpoint
14	DI trigger	-	1
15	Setpoint trigger	-	1
16	Source 1..14	-	Internal measures
17	Group 1..14	-	Instantaneous-Average-Energies-Digital input-Counter-Analog input-Math-Energy TB1..16-Harmonics VL1..VL3- Harmonics IL1..IL3-Diagnostic
18	Item 1..14	-	OFF-(measures)

- 1 - Enable or disable the data logger function. Every record is marked with a timestamp taken from the real-time clock.

**ALWAYS** - The data logger allows to store at regular intervals up to 14 variables. The recording is continuous (driven only by regular time intervals).

**BETWEEN DATE** - The recording allows to store at regular intervals only between a specified date range.

**BETWEEN HOUR** - The recording allows to store at regular intervals only in the specified time interval.

**BETWEEN DATE AND HOUR** - The recording allows to store at regular intervals between a specified date range and time interval.

**TRIGGER** - The recording allows to store at regular intervals driven only by the status of the internal variables (setpoint) or digital input status.

2 - Time interval between a data reading and the next one.

3 - When the memory is full, you can choose to stop the recording (End Memory mode) or to continue overwriting the oldest records (FIFO mode).

4, 5, 6, 7 - Set the variables (driven by date range or/and time interval) that control the starting of the recording.

8, 9, 10, 11 - Set the variables (driven by date range or/and time interval) that control the ending of the recording.

12 - The recording can be disabled for a specific day of the week.

13 - Set the internal variables (setpoint) or digital input status to allows the recording.

14 - Define the number of digital input which controls the starting/ending of the recording.

15 - Define which setpoint controls the starting/ending of the recording.

16 - The data logger allows to store at regular interval up to 14 variables. To configure the data logger, it's necessary to select the source variables (network analyzer's measures or from external devices).

17 - The data logger allows to store at regular interval up to 14 variables. To configure the data logger, it's necessary to select the group variables.

18 - The data logger allows to store at regular interval up to 14 variables chosen freely among the network analyzer's measures or from external devices.

SMART		UoM	Default	Range
1	Enable	-	OFF	OFF-Always-Between date-Between hour- Between date and hour-Trigger
2	Sampling	-	15 min	1-2-3-5-6-10-12-15-20-30-60 min End of day End of month
3	Storage	-	End memory	End memory / FIFO
4	Group 1..14	-	-	Instantaneous
5	Item 1..14	-	-	OFF-(measures)

**NOTE:** the Smart data logger allows to store at regular interval:

1. The instantaneous value that the variable had at the moment of sampling.

2. The average value that the variable had in the sampling period.

3. The maximum value that the variable reached in the sampling period.

4. The minimum value that the variable reached in the sampling period.

Every record is marked with a timestamp taken from the real-time clock.

#### **LOGIC EXPRESSION menu**

LOGIC EXPRESSION n (n=1..8)		UoM	Default	Range
1	Enable	-	NO	YES-NO
2	Compute timing	sec/min	1 sec	1-2-3-5-6-10-12-15-20-30 sec 1-2-6-5-6-10-12-15-20-30-60 min End of day End of week End of month
3	Source 1	-	-	Internal measures-(measures node 1-20)
4	Group 1	-	-	Instantaneous-Average-Energies- Digital inputs-Counters-Analog input-Math
5	Item 1	-	-	OFF-(measures)
6	Multiplier 1	-	1	1-100000
7	Divisor 1	-	1	1-100000
8	Operation	-	Sum	Sum-Subtraction-Multiplication-Division
9	Source 2	-	-	Internal measures-(measures node 1-20)
10	Group 2	-	-	Instantaneous-Average-Energies- Digital inputs-Counters-Analog input-Math
11	Item 2	-	-	OFF-(measures)
12	Multiplier 2	-	1	1-100000
13	Divisor 2	-	1	1-100000

**NOTE:** this menu is divided into 8 sections, for logic expression LE1..8

1 - Expression enabled.

2 - Selection of refresh calculation. Expression value is updated with the results of the last calculation.

3 - First measurement source. Internal measures or measures referred to the external devices (when EMA-D6 will be configured as Master RS-485).

4 - First measurement group that generates the alarm.

5 - Define which measurement of the device as the first operand.

6 - Multiplying factor referred to previous measurement.

7 - Dividing factor referred to previous measurement.

8 - Math operation between first and second operands.

9, 10, 11, 12, 13 - (see above).

**Info menu**

Menu	Description
Device	Serial number-Revision software-Revision hardware-Info wiring-Work hours-Communication info-MAC address-Options info installed
I/O	Digital input/output status-Analog output status
Setpoint	Info setpoints
Date/Time	Time and date
COM monitor	Communication traffic (RS-485 and Ethernet)
Log summary	Info logs
Log details	Viewing logs
ON/OFF events	Power supply switch ON/OFF

**Connections**

MODBUS / M-BUS connection

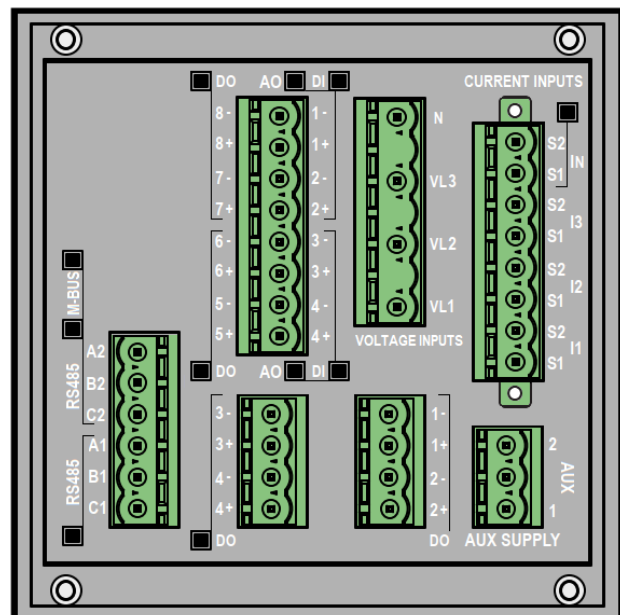

PROFIBUS connection

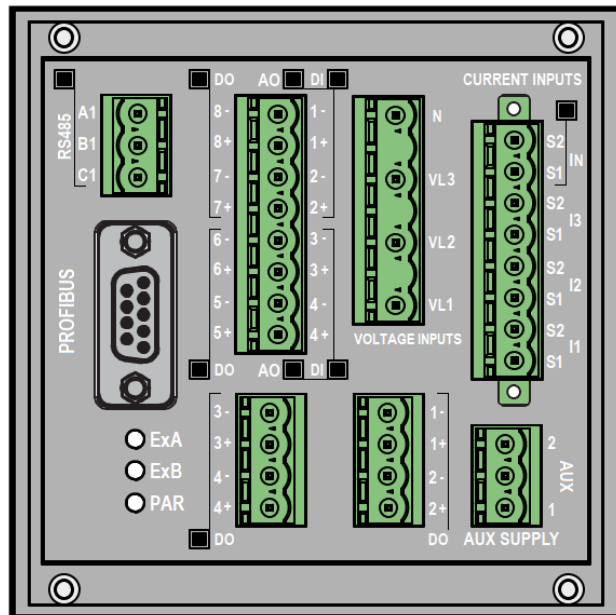

ETHERNET(ETH-WEB) connection

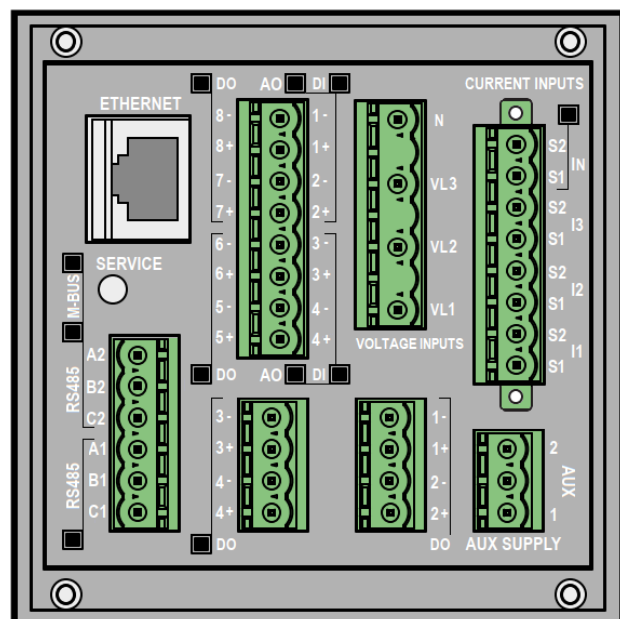

ETHERNET(ETH-MOD) connection

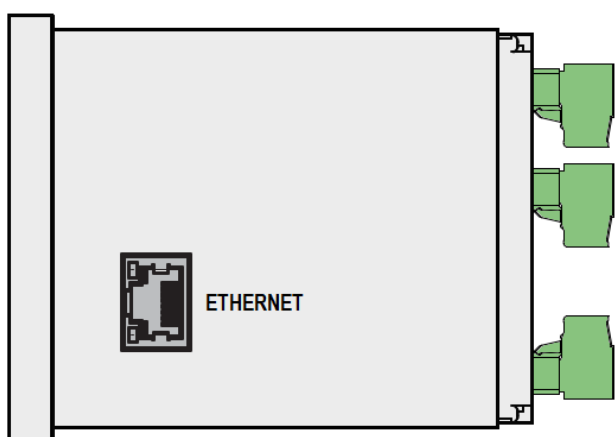

## Mechanical dimensions (mm)

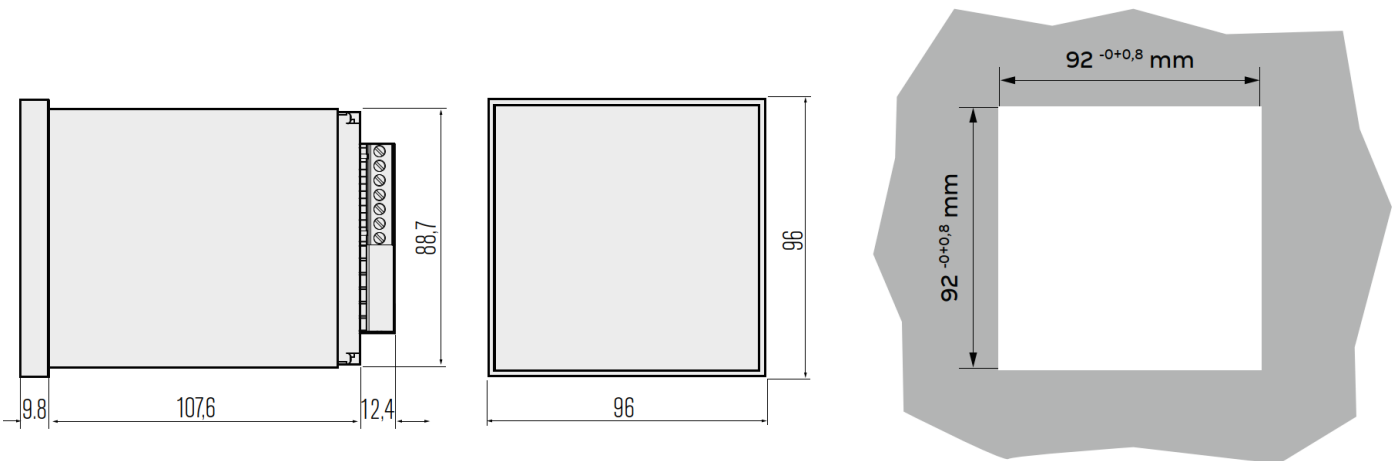

## Acronyms table of Instantaneous group

Acronym	Description
ΣV	System Voltage
V1	Voltage L1
V2	Voltage L2
V3	Voltage L3
V1-V2	L1-L2 Voltage
V2-V3	L2-L3 Voltage
V3-V1	L3-L1 Voltage
ΣA	System Current
A1	Current L1
A2	Current L2
A3	Current L3
ΣPF	System Power Factor
PF1	Power Factor L1
PF2	Power Factor L2
PF3	Power Factor L3
ΣCOS	System COS
COS1	COS L1
COS2	COS L2
COS3	COS L3

Acronym	Description
ΣVA	System Apparent Power
VA1	Apparent Power L1
VA2	Apparent Power L2
VA3	Apparent Power L3
ΣW	System Active Power
W1	Active Power L1
W2	Active Power L2
W3	Active Power L3
ΣVar	System Reactive Power
Var1	Reactive Power L1
Var2	Reactive Power L2
Var3	Reactive Power L3
4° A	4 <sup>th</sup> Current Input
FREQ	Frequency
INT TEMP	internal temperature
THD V1	THD Voltage L1
THD V2	THD Voltage L2
THD V3	THD Voltage L3
THD A1	THD Current L1

Acronym	Description
THD A2	THD Current L2
THD A3	THD Current L3
DEG V1-V2	Phase Angle L1-L2
DEG V2-V3	Phase Angle L2-L3
DEG V3-V1	Phase Angle L3-L1
ΣTAN	System Tangent
TAN1	Tangent L1
TAN2	Tangent L2
TAN3	Tangent L3
ΣEXP W	System Expected Power
EXP W1	Expected Power L1
EXP W2	Expected Power L2
EXP W3	Expected Power L3
DEG V-A 1	Phase Angle V1-A1
DEG V-A 2	Phase Angle V2-A2
DEG V-A 3	Phase Angle V3-A3

## Acronyms table of Average group

Acronym	Description
AVG ΣV	System Average Voltage
AVG V1	Average Voltage Phase 1
AVG V2	Average Voltage Phase 2
AVG V3	Average Voltage Phase 3
AVG ΣA	System Average Current
AVG A1	Average Current L1
AVG A2	Average Current L2
AVG A3	Average Current L3
AVG ΣPF	System Average Power Factor
AVG PF1	Average Power Factor L1
AVG PF2	Average Power Factor L2
AVG PF3	Average Power Factor L3

Acronym	Description
AVG ΣCOS	Average COS L1
AVG COS1	Average COS L2
AVG COS2	Average COS L3
AVG-COS3	System Average Apparent Power
AVG ΣVA	Average Apparent Power L1
AVG VA1	Average Apparent Power L2
AVG VA2	Average Apparent Power L3
AVG VA3	System Average Active Power
AVG ΣW	Average Active Power L1
AVG W1	Average Active Power L2
AVG W2	Average Active Power L3
AVG W3	Average COS L1

Acronym	Description
AVG ΣVar	System Average Reactive Power
AVG VAR1	Average Reactive Power L1
AVG VAR2	Average Reactive Power L2
AVG VAR3	Average Reactive Power L3
AVG 4° A	4 <sup>th</sup> Current Input
AVG Hz	Average Frequency
AVG ΣTAN	Average System Tan
AVG TAN1	Average Tangent L1
AVG TAN2	Average Tangent L2
AVG TAN3	Average Tangent L3

## Acronyms table of Energies and TB (from 1 to 16) groups

Acronym	Description
ΣWh IN	System Active Energy IN
ΣWh OUT	System Active Energy OUT
ΣVArh IN	System Reactive Energy IN
ΣVArh OUT	System Reactive Energy OUT
ΣVAh	System Apparent Energy
Wh IN 1	Active Energy L1 IN
Wh OUT 1	Active Energy L1 OUT

Acronym	Description
VArh IN 1	Reactive Energy L1 IN
VArh OUT 1	Reactive Energy L1 OUT
VAh 1	Apparent Energy L1
Wh IN 2	Active Energy L2 IN
Wh OUT 2	Active Energy L2 OUT
VArh IN 2	Reactive Energy L2 IN
VArh OUT 2	Reactive Energy L2 OUT

Acronym	Description
VAh 2	Apparent Energy L2
Wh IN 3	Active Energy L3 IN
Wh OUT 3	Active Energy L3 OUT
VArh IN 3	Reactive Energy L3 IN
VArh OUT 3	Reactive Energy L3 OUT
VAh 3	Apparent Energy L3

## Technical features

<b>Auxiliary power supply</b>	
Rated voltage	90±250 VAC/DC 20±60 VAC/DC
Frequency	50/60 Hz
Protection fuse	5x20 mm - 1A time lag (option 90±250 Vac/dc)   5x20 mm - 3.15A time lag (option 20±60 Vac/dc)
Power consumption	10VA max – 3VA min (depending on the options and activities)
<b>Voltage inputs</b>	
Type of input	Three phase + neutral
Maximum rated voltage	830 VAC phase-phase 480 VAC L-N
Measurement range	30 - 400 VAC L-N 52 - 693 VAC L-L
Input resistance	>1.8MΩ
Frequency range	50 - 60 Hz Note: V1 terminal must be connected
Method of measuring	True RMS value
Load (Burden) for each input	0.09 VA
<b>Current inputs</b>	
Type of input	Inputs isolated by internal current transformers
Measurement range	for 5A scale: 50mA - 5A for 1A scale: 10mA - 1A
Method of measuring	True RMS value
Maximum continuous overload 1A	1.3A
Maximum continuous overload 5A	6.5A
Load (Burden) for each input	0.001 V <sub>MAX</sub>
<b>Accuracy</b>	
Energy	CEI EN 62053-21 compliant – Class 1 (1%) CEI EN 62053-22 compliant – Class 0.5 S (0.5%) CEI EN 62053-22 compliant – Class 0.2 S (0.2%)
Frequency	40 - 70 Hz
Power factor	± 1.000
Cosφ	± 1.000
THD	IEC62053-22 compliant
Harmonics	up to 21 <sup>th</sup> Harmonics – IEC62053-22
Refresh rate	~ 1000 mS
<b>Ambient conditions</b>	
Operating temperature	-20... +60°C
Storing temperature	-30... +80°C
Relative humidity	5...95%
Altitude	≤2000m
<b>Housing</b>	
Overall dimension	96x96x130 mm
Degree of protection	IP50 on front (IP65 with frontal transparent cover) IP20 housing and terminals
Weight	450 gr
<b>Communication RS485</b>	
Protocol	Modbus RTU
Standard	RS485 half-duplex with optical isolation
Baud rate	4.8 – 9.6 – 19.2 – 38.4 – 57.6 – 115.2 kbps
Node	1 ÷ 247
Parity	Even - Odd – None
Stop bit	1, 2
<b>Communication Profibus</b>	
Protocol	Slave DP-V0
Baud rate	9.6Kbits/s - 3Mbits/s
Node	0-126
Connector	DB 9 female connector
<b>Communication Ethernet</b>	
Protocol	ModbusTCP
Connector	RJ45
<b>Communication MBUS</b>	
Baud rate	0.3 - 0.6 - 1.2 - 2.4 - 4.8 - 9.6 - 19.2 - 38.4 kbps
Node	0-250
Parity	Even - Odd – None
Stop bit	1, 2
<b>Digital input</b>	
Number of digital inputs	2, 4
Input voltage range	Input rated voltage V <sub>INPUT</sub> 24, 48, 115, 230 Vac/dc (only one defined in the order)

Input current	Rated input current $I_{INPUT}$ @ $V_{INPUT}$ : $5mA_{MAX}$ @ $V_{INPUT}=all$ voltages	
Inputs configuration	2 terminals (A-K) for each input: NPN, PNP	
Isolation voltage	3.5KV for 60 sec.	
Input filter	Digital	
Pulse duration	$T_{ON\_min}$ 30ms, $T_{OFF\_min}$ 30ms	
<b>Digital output</b>		
Number of digital outputs	2, 4, 6, 8	
Type	Photo-MOS (solid state); $R_{ON}=8\Omega$ typ. (12 $\Omega$ MAX)	
Range Voltage/Current	10 ÷ 300Vcc 150mA <sub>MAX</sub> ; 12 ÷ 250Vca 150mA <sub>MAX</sub>	
Isolation voltage	4KV per 60 sec.	
Output functionality	Programmable output as pulse / status / alarm.	
Minimum impulse period	$T_{ON\_min}$ 30ms, $T_{OFF\_min}$ 30ms	
<b>Analog output</b>		
Number of analog outputs	2, 4	
Auxiliary power supply	Not required	
Insulation level	3.5KV for 60 sec.	
Maximum length of connection	1200m	
Resolution	12bit (4096 valori)	
Analog outputs type	Current	Voltage (only with V,I option)
Mode	0÷20mA or 4÷20mA	0÷10V or -10÷10V or 0÷5V or -5÷5V
Load	Max 600 $\Omega$	Min 1K $\Omega$
Error	Max: 0.5% on E.S. – Typical 0.2% on E.S.	Max: 0.3% on E.S. – Typical 0.1% on F.S.
	Linearity: 0.01 on F.S. - Thermal stability: 0.01 on F.S.	
Settling time	50 $\mu$ s(0÷20mA)@ $R_{LOAD}=1K\Omega$ , $C_{LOAD}=200pF$ , $L_{LOAD}=1mH$	50 $\mu$ s(-10 ÷10V)@ $R_{LOAD}=1K\Omega$ , $C_{LOAD}=200pF$
<b>Clock calendar</b>		
Date and time	Hours, minutes, seconds, day of week, date, month, year	
Retention (in absence of voltage)	~7 days	
<b>Memory</b>		
Standard memory	100 KB	
<b>Certifications and compliance</b>		
References standards	CEI EN 61000-6-2:2006 CEI EN 61000-6-4:2007 CEI EN 61010-1:2013	

For further details please contact:

**Contrel elettronica s.r.l.**

Via San Fereolo, 9

I-26900 Lodi

Tel: +39 0371 30207 / 30761 / 35386

**[www.contrel.it](http://www.contrel.it)**

:

